

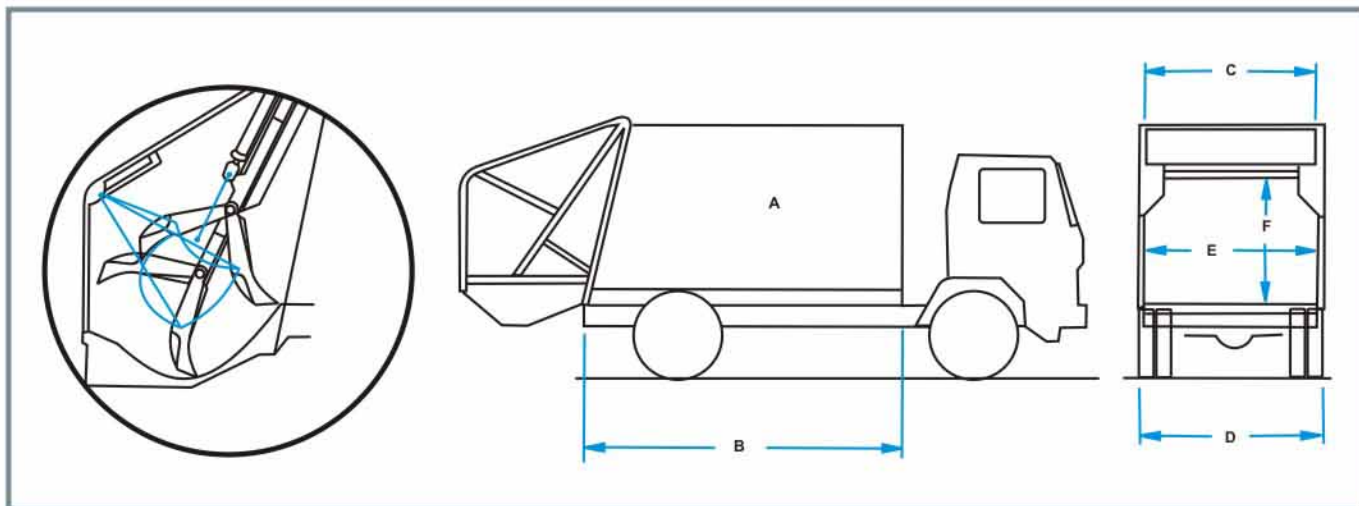

Sierra S120



Sierra S120

Sierra S120	
Body capacity	12.00m ³
Hopper capacity	1.32 m ³
Total capacity	13.32 m ³
A - Height above chassis frame	1997mm
B - Body length	3693mm
C - Body inside width	2155mm
D - Body outside width	2316 m
G - Hopper opening	2080 x 1550 mm
Approx. body weight	4.050kg

FEATURES

- Smooth body construction
- Full exterior continuous welds for greater strength and liquid sealing
- Constructed with high tensile and abrasion resistant steel
- Rubber gasket forms liquid tight seal around bottom and sides of tailgate.
Curbside dual lever packing controls with automatic reset and automatic engine accelerator.
- Able to stop and reverse packing cycle at any time.
- Ejection by a double-acting telescopic cylinder.
- Manual tailgate locking mechanism.
- Steps and grab handles for 4 personal.
- Buzzer system enables loader to signal driver.
- Lighting in accordance with transit standards.
- Loading sill below chassis frame: 25mm.
- Packing cycle time: 20/22 seconds.
- Disposal cycle time: 18/22 seconds.
- Meets all safety standards.
- Dual level ejection and tailgate lift controls at front of body curbside
- 2K automotive paint finish.

HYDRAULIC SYSTEM

- 1 Gear pump with capacity of 80 LPM @ 1000 RPM
- 2 Double acting packer cylinders
- 2 Double acting carrier cylinders
- 1 Double acting telescopic ejection cylinder
- 2 Single acting tailgate lift cylinders
- All cylinders are chrome plated
- Hydraulic tank capacity of 100 litres with sight glass
- In-line strainer inside of tank
- Return line filter
- Operating pressure: 180 Bar
- Packer & carrier cylinder rods - induction hardened

OPTIONAL EQUIPMENT

- Container handling system for use with metallic containers from 0.8 to 1.6m² and 3.0 to 4.0m²
- Cart lifter system for use with 2 or 4 wheels.
- Device to protect undue operation of the ejection plate
- Anti-acceleration device for protection of the engine
- Strobe safety lighting
- Night light in hopper
- PTO (Power Take Off)

The specifications can be changed without notice

Branches and distributors throughout Southern Africa, each with sales, spares and workshop facilities.

National telephone 086 11 600SA

Head Office

17 Derrick Road, Spartan, Kempton Park.
Gauteng, South Africa
PO Box 600, Kempton Park 1620
Tel: 086 11 600SA Fax: 011 573 2334
e-mail: jhbsales@600sa.co.za
Web: www.600sa.co.za

Branches

- Durban
- Johannesburg
- Machine Tools
- Nelspruit
- Polokwane

Distributors

- Port Elizabeth
- Cape Town
- East London
- Ermelo
- George
- Bloemfontein
- Botswana
- Namibia



... enhancing your success